

3

COMPRESSOR MOTOR AND COMPONENT INFORMATION

- I. Single Phase Compressor Motor Types . 16
- II. PSC Motor Starting 18
- III. Hermetic Compressor Thermal
Protectors 19
- IV. Compressor Motor Starting Relays 27
- V. Selecting Capacitors 32
- VI. Identification of Terminal Pins 34
- VII. Fuse and Circuit Breaker Sizing 36

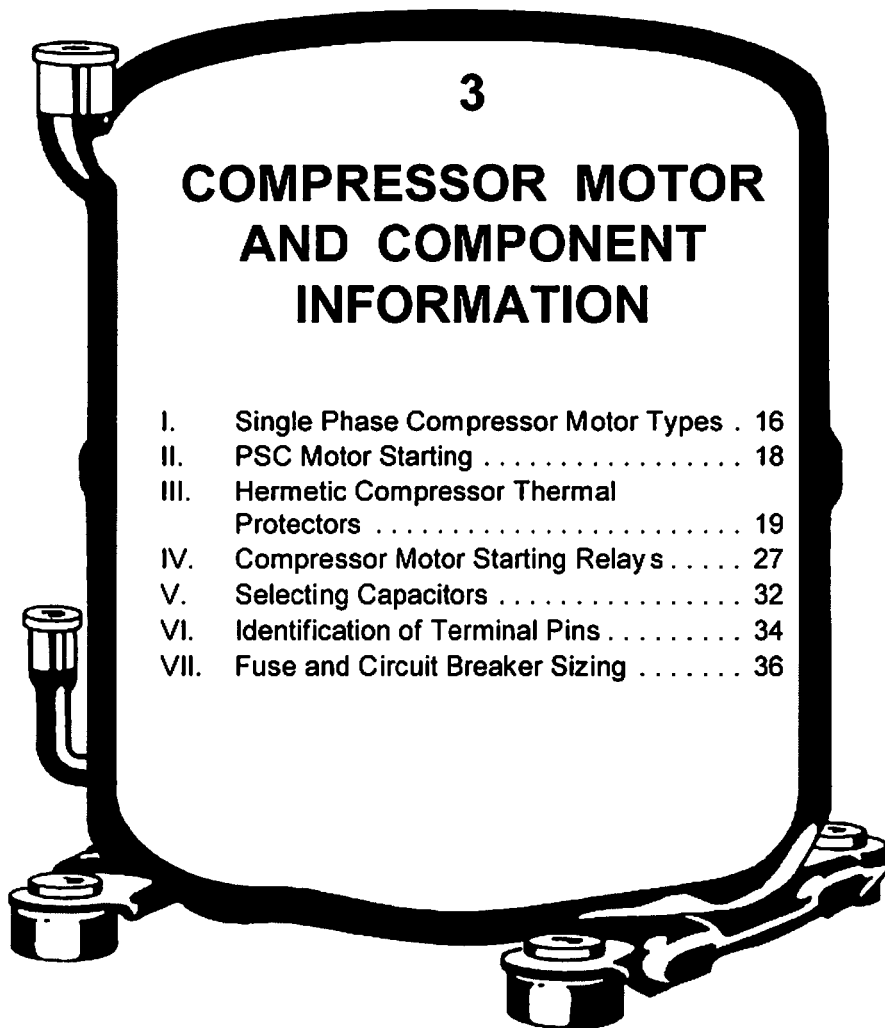

I. Single Phase Compressor Motor Types

Tecumseh hermetic compressors contain motors designed for specific requirements of starting torque and running efficiency. There are four general types of single phase motors, each distinctly different from the others. Each type of motor may have two to four different configurations depending on the compressor components.

A. Resistance Start—Induction Run (RSIR)

This motor, also known as a split-phase motor, is used on many small hermetic compressors up through 1/3 HP. The motor has low starting torque and must be applied to completely self-equalizing capillary tube systems such as household refrigerators, freezers, small water coolers, and dehumidifiers. This motor has a high resistance start winding which is not designed to remain in the circuit after the motor has come up to speed. A relay is necessary to perform the function of disconnecting the start winding as the motor comes up to design speed. Three types of relays are used with this motor:

- a current relay,
- a wired-in Positive Temperature Coefficient (PTC) relay, or
- a module Positive Temperature Coefficient (PTC).

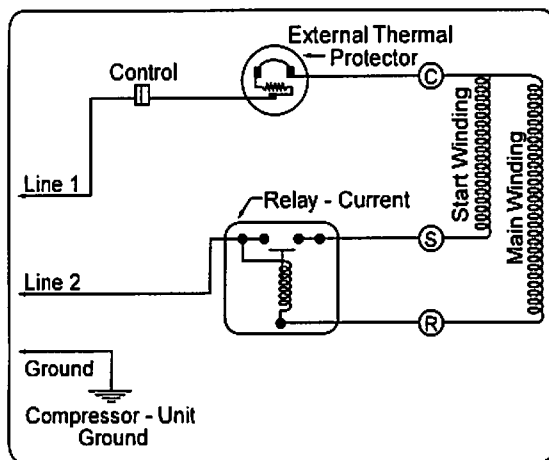

Figure 3-1. RSIR motor diagram with current relay.

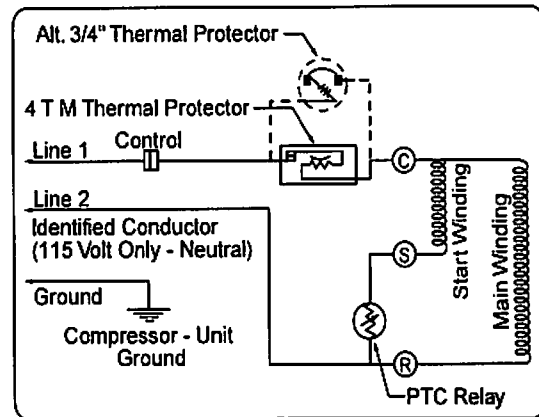

Figure 3-2. RSIR motor diagram with wired-in PTC relay.

B. Capacitor Start—Induction Run (CSIR)

The CSIR motor is similar to RSIR except a start capacitor is included in series with start winding to produce a higher starting torque. This is commonly used on commercial refrigeration systems through 3/4 HP. Two types of relays are used with this motor:

- a current relay, or
- a potential relay.

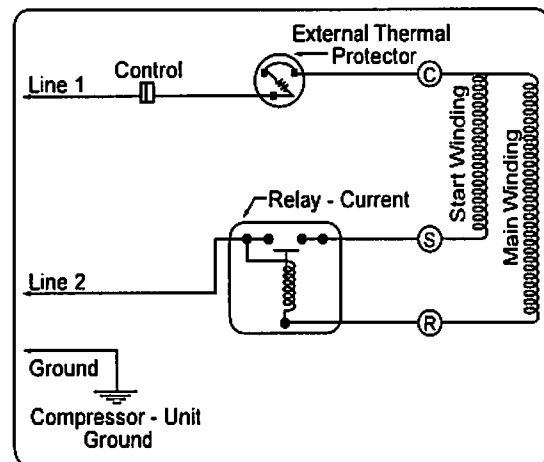

Figure 3-3. CSIR motor diagram.



C. Capacitor Start and Run (CSR)

This motor arrangement uses a start capacitor and a run capacitor in parallel with each other and in series with the motor start winding. This motor has high starting torque, runs efficiently, and is used on many refrigeration and air conditioning applications through 5 HP. A potential relay removes the start capacitor from the circuit after the motor is up to speed. This motor may use either:

- an external thermal protector, or
- an internal thermal protector.

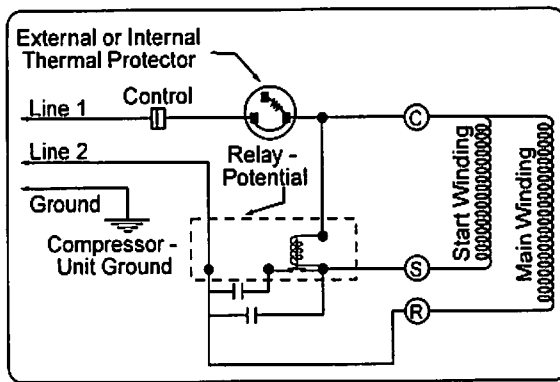

Figure 3-4. CSR motor diagram.

D. Permanent Split Capacitor (PSC)

Here a run capacitor is in series with the start winding. Both run capacitor and start winding remain in the circuit during start and after motor is up to speed. This normal starting torque motor is sufficient for capillary and other self-equalizing systems. No start capacitor or relay is necessary. For additional starting torque, a proper start assist kit may be added (see Figure 3-6). Some start assist kits may include:

- a wired-in Positive Temperature Coefficient (PTC) relay, or
- a module Positive Temperature Coefficient (PTC) relay.

This motor may use either:

- an external thermal protector, or
- an internal thermal protector.

PSC motors are basically air conditioning compressor motors and are very common up through 5 HP.

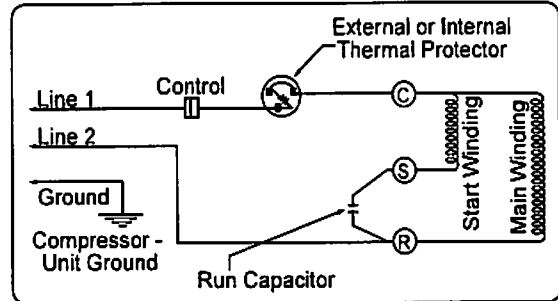

Figure 3-5. PSC motor diagram.

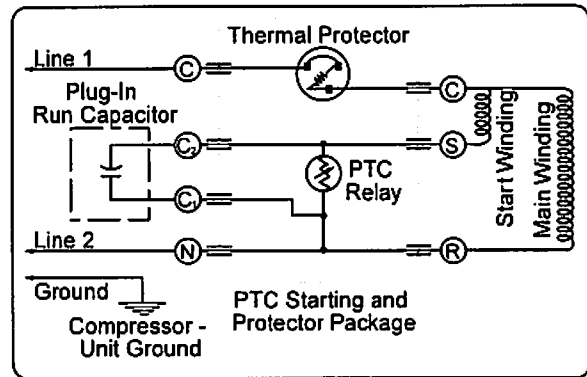

Figure 3-6. PSC motor diagram with start assist kit that includes a module PTC relay.

II. PSC Motor Starting

Tecumseh Products Company has pioneered in encouraging the development of Permanent Split Capacitor compressor motors. This type of motor eliminates the need for potentially troublesome and costly extra electrical components (start capacitors and potential motor starting relays). (See Figure 3-7.)

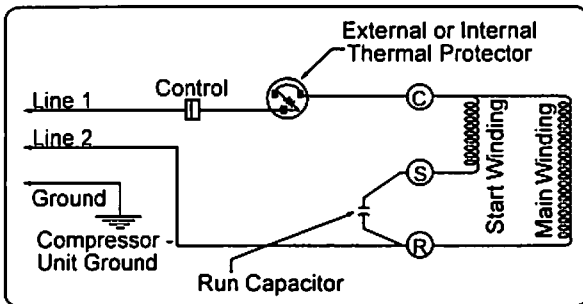

Figure 3-7. Circuit diagram for PSC compressors.

To fully realize the capabilities of this simplified type of compressor motor, it is necessary to understand its starting and operating characteristics and the field conditions which can affect it.

The following conditions affect PSC motor starting:

- **Low voltage:** Reduces motor starting and running torque. A 10% voltage drop reduces a motor's starting ability by 19%. Low voltage can cause no start, hard start, light flicker, and TV screen flip flop.

Minimum starting voltage for the compressor when it is attempting to start (locked rotor) is:

Table 3-7: Minimum Starting Voltage

Serial Label Voltage	Min. Voltage for Start
115	103
208	188
230	207
230/208	198
265	239

- **Unequalized system pressure:** Head and suction pressures must be equal and not more than 170 psig. Refrigeration metering device (cap tube or TX valve) should equalize system pressures within 3 minutes. Unequal system pressure may be caused by excessive refrigerant charge, short cycling thermostat, or system restriction.
- **Circuit breaker or fuse trips:** Branch circuit fuses or circuit breakers sized too small will cause nuisance tripping (see "Fuse and Circuit Breaker Sizing" on page 36). If the fuse or circuit breaker trips, see "Identifying Compressor Electrical Problems" on page 47 for electrical troubleshooting techniques.
- **Electrical components:** A failed run capacitor will not allow the compressor to start, and it will trip the thermal protector. See "Identifying Compressor Electrical Problems" on page 47 for electrical troubleshooting techniques.

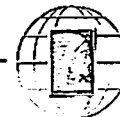

III. Hermetic Compressor Thermal Protectors

Hermetic compressor motors are protected from overheating by thermal protectors built into or mounted in contact with the compressor motor. See the Electrical Service Parts Guide Book for correct replacement thermal protectors. Typical wiring diagrams are shown on pages 51 to 82.

The thermal protector device (see Figure 3-8), when firmly attached to the compressor housing, quickly senses any unusual temperature rise or excess current draw. The bi-metal disc within the thermal protector (see Figure 3-9) reacts to either excess temperature and/or excess current draw by flexing downward, and disconnecting the compressor from the power source.

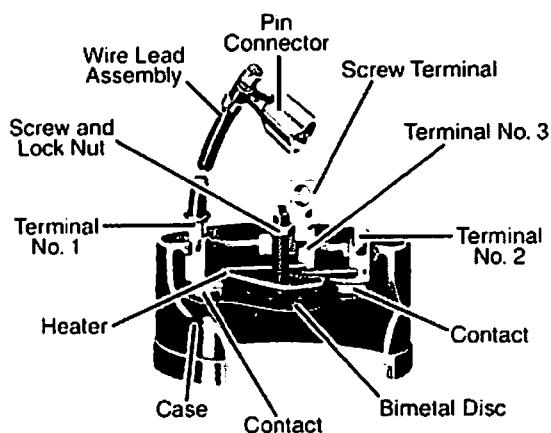

Figure 3-8. External thermal protector. (Models AE, TP, TH, AK, AJ, CAJ, AZ, RK, RG, TW, and some CL.)

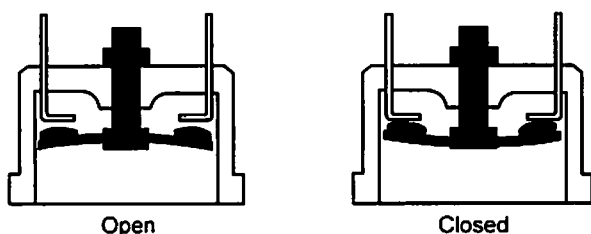

Figure 3-9. Bi-metal disc.

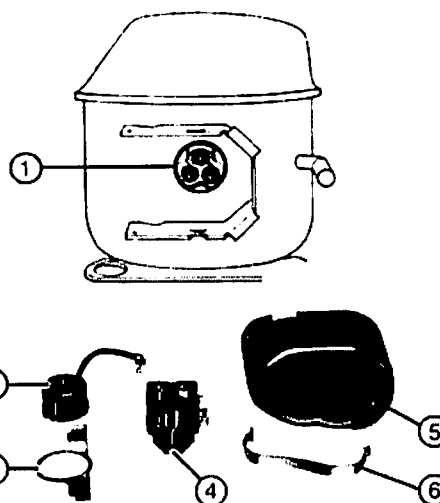

Figure 3-10. AE refrigeration compressor showing (1) hermetic terminal, (2) thermal protector, (3) thermal protector clip, (4) push-on relay, (5) protective terminal cover, and (6) bale strap.

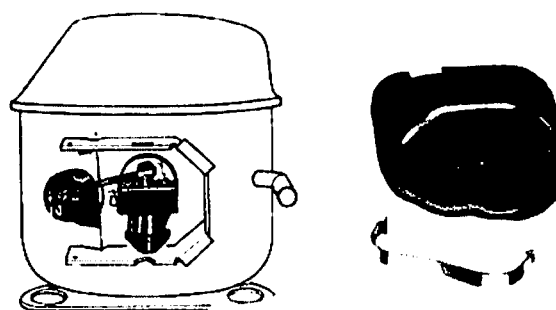

Figure 3-11. AE refrigeration compressor with the thermal protector and relay assembled.



IV. Compressor Motor Starting Relays

A hermetic motor starting relay is an automatic switching device to disconnect the motor start capacitor and/or start winding after the motor has reached running speed.

Never select a replacement relay solely by horsepower or other generalized rating. Select the correct relay from the Tecumseh Electrical Service Parts Guide Book.

There are two types of motor starting relays used in refrigeration and air conditioning applications: the current responsive type and the potential (voltage) responsive type.

A. Current Type Relay

When power is applied to a compressor motor, the relay solenoid coil attracts the relay armature upward causing bridging contact and stationary contact to engage. This energizes the motor start winding. When the compressor motor attains running speed, the motor main winding current is such that the relay solenoid coil de-energizes allowing the relay contacts to drop open thereby disconnecting motor start winding.

The relay must be mounted in true vertical position so armature and bridging contact will drop free when relay solenoid is de-energized.

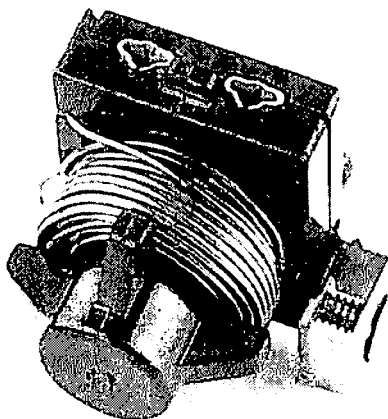

Figure 3-17. Current type relay.

B. PTC Type Relay

Solid state technology has made available another type of current sensitive relay—a PTC starting switch. Certain ceramic materials have the unique property of greatly increasing their resistance as they heat up from current passing through them. A PTC solid state starting device is placed in series with the start winding and normally has a very low resistance. Upon startup, as current starts to flow to the start winding, the resistance rapidly rises to a very high value thus reducing the start winding current to a trickle and effectively taking that winding out of operation.

Usage is generally limited to domestic refrigeration and freezers. Because it takes 3 to 10 minutes to cool down between operating cycles, it is not feasible for short cycling commercial applications.

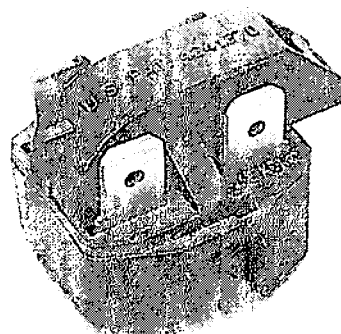

Figure 3-18. PTC type relay.

C. Potential Type Relay

Generally used with large commercial and air conditioning compressors (capacitor start, capacitor run) to 5 HP. Relay contacts are normally closed. The relay coil is wired across the start winding and senses voltage change. Starting winding voltage increases with motor speed. As the voltage increases to the specific pickup value, the armature pulls up, opening the relay contacts, de-energizing the start winding capacitor. After switching, there is still sufficient voltage induced in the start winding to keep the

relay coil energized and the relay starting contacts open. When power is shut off to the motor, the voltage drops to zero, the coil is de-energized, and the start contacts reset.

When changing a compressor relay, care should be taken to install the replacement in the same position as the original.

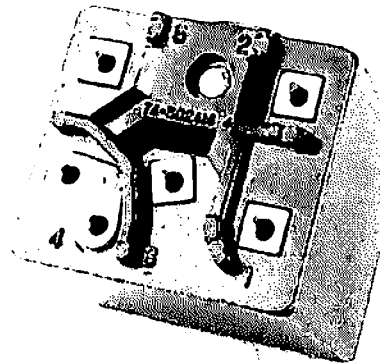

Figure 3-19. Potential type relay.

Table 3-7: Facts About Starting Relays

Relay Type	Compressor Motor Type	Characteristics
Current Relay	RSIR and CSIR	<ul style="list-style-type: none"> • Sense starting current to main (run) windings • Contacts normally open • Contacts close and then release in less than 1 second as motor starts • Must be installed vertically since contacts open by gravity
PTC Relay	RSIR and PSC	<ul style="list-style-type: none"> • Sense starting current to start winding • Solid state device whose resistance increases with heat from current as motor starts • Takes 3 to 10 minutes to cool down between operating cycles
Potential Relay	CSR	<ul style="list-style-type: none"> • Sense voltage generated by start winding • Contacts normally closed • Contacts open in less than 1 second as motor starts



Potential Type Relay Supplier Code Designations

In recent years, Tecumseh has used an increasing number of potential relays with hermetic compressors. A large number of these have been used on air conditioning applications, but there are also many other applications. Since there are many variations with regard to these relays such as number of terminals, coil group, hot pick up, and mounting posi-

tion, an explanation of the code numbers should be useful in the field.

Tecumseh has two major suppliers of potential relays: the General Electric Company and the supplier of White Rodgers relays. An explanation of the code designation for relays manufactured by each of these companies is provided in Figures 3-20 and 3-21.

Example: 3ARR3-A5C3

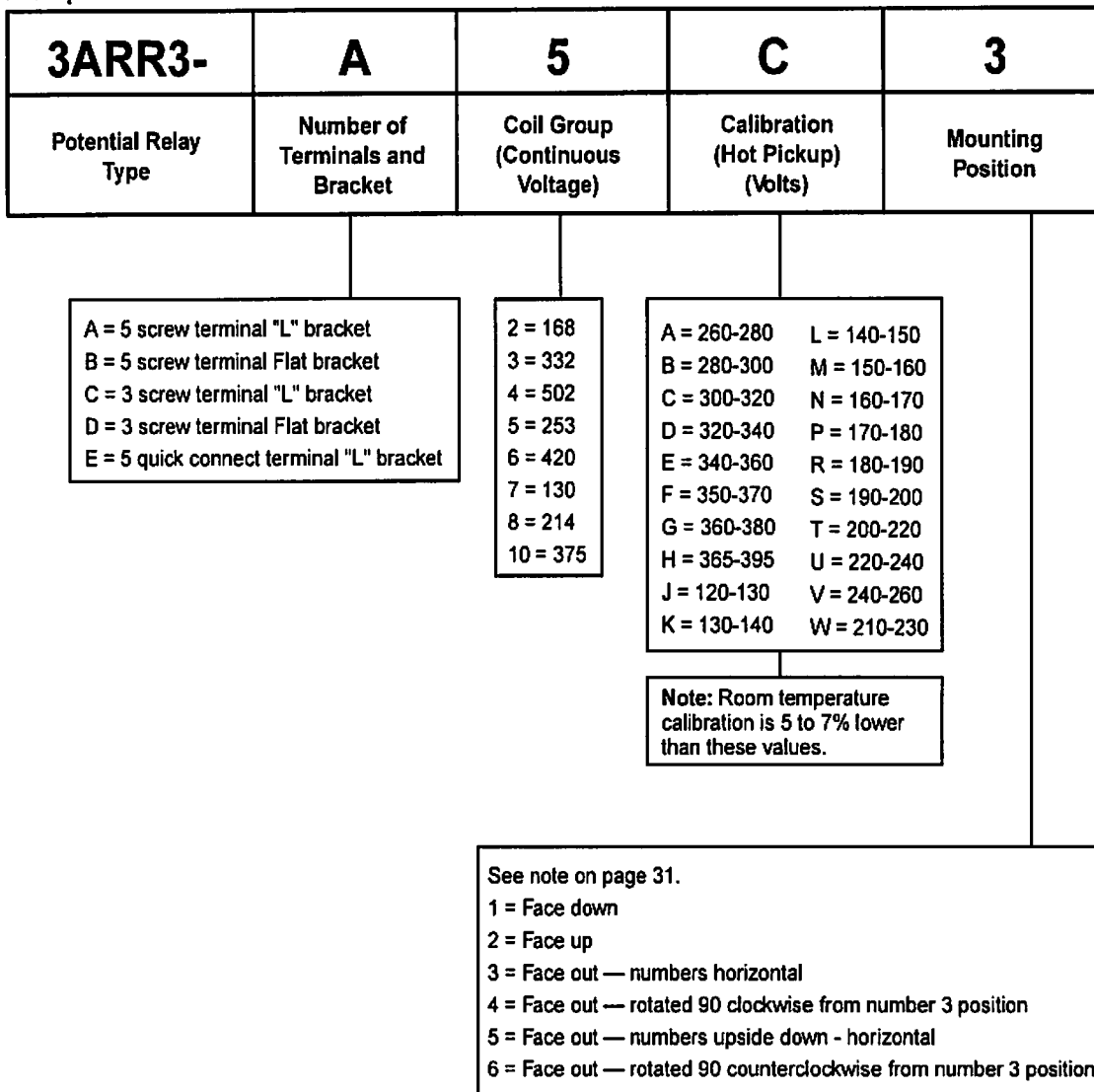

Figure 3-20. Explanation of GE Potential Relay Code.

Example: 128-122-1335CA

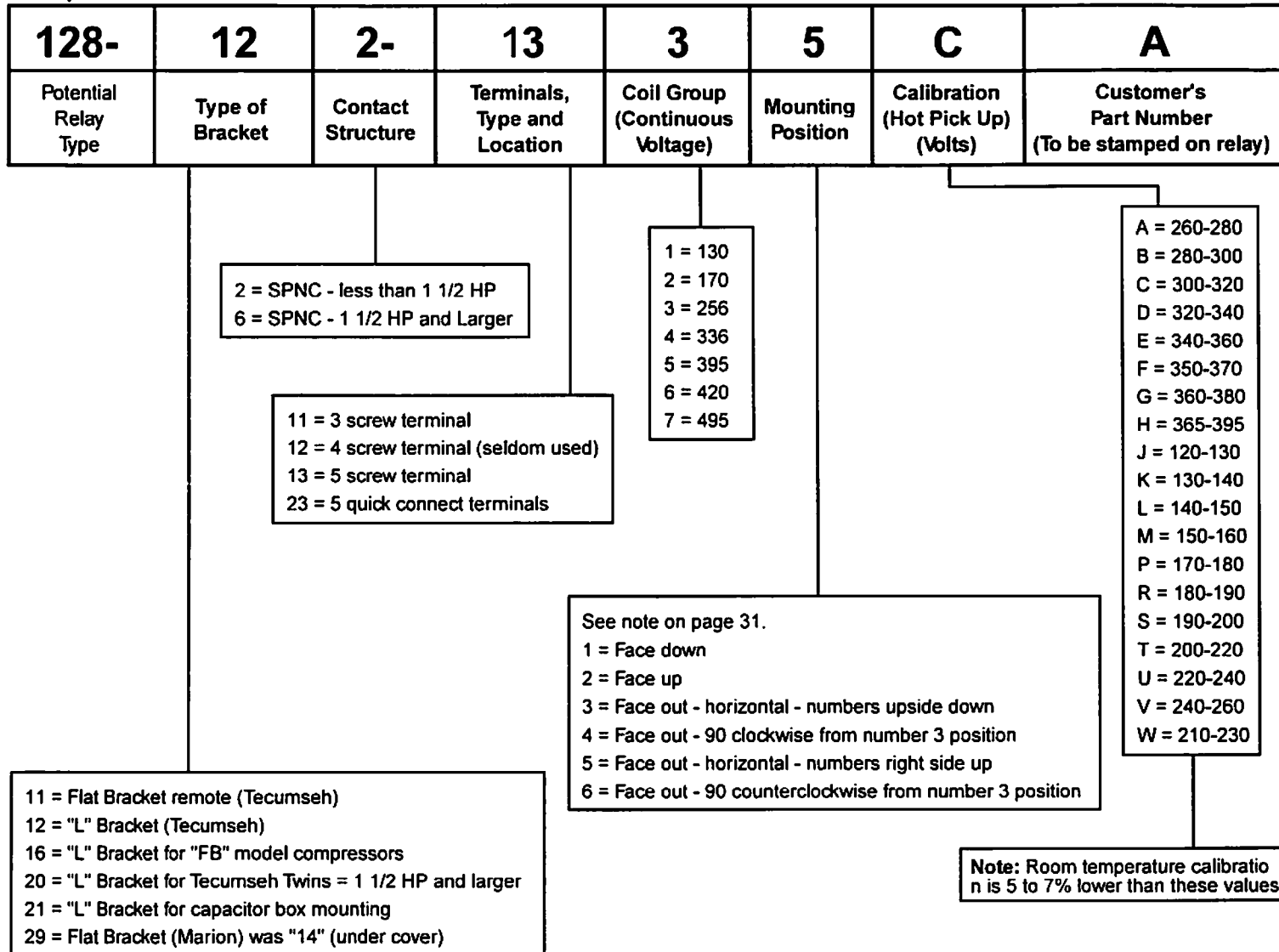

Figure 3-21. Explanation of White Rodgers Potential Relay Code.



NOTE: As noted above, the 4th digit in the code number of G.E. relays and the 7th digit for White Rodgers relays indicates the position in which the relay is to be mounted. It is of utmost importance that the relay be mounted in the required posi-

tion. Mounting in any other position can change the relay's operating characteristics enough so that the compressor will not start properly. This can result in compressor motor failure.

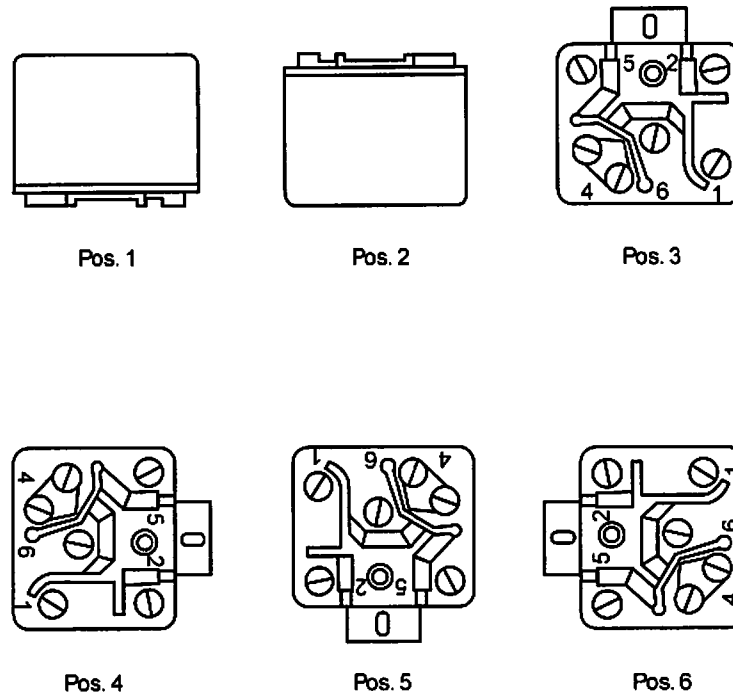

Figure 3-22. Potential type relay mounting positions.

V. Selecting Capacitors

Never use a capacitor with a lower voltage rating than that specified. A higher voltage rating than that specified is acceptable.

A. Start Capacitor Bleeder Resistors

Modern high power factor, low current single phase compressor motors which require start and run capacitors used with potential type relays can create electrical circuits which could cause starting relay damage resulting in compressor failure.

The high voltage stored in the start capacitor could discharge across the contacts of the starting relay thus welding them and preventing the relay from functioning. Capacitor failure and/or start winding failure could result.

To eliminate this, Tecumseh Products Company start capacitors are equipped with bleeder resistors wired across the capacitor terminals. No start capacitor used in conjunction with a potential relay and run capacitor should be installed without such a bleeder resistor.

In an emergency where no bleeder resistor equipped capacitors are available, then a two watt 15,000 ohm resistor can be obtained and soldered across the capacitor terminals.

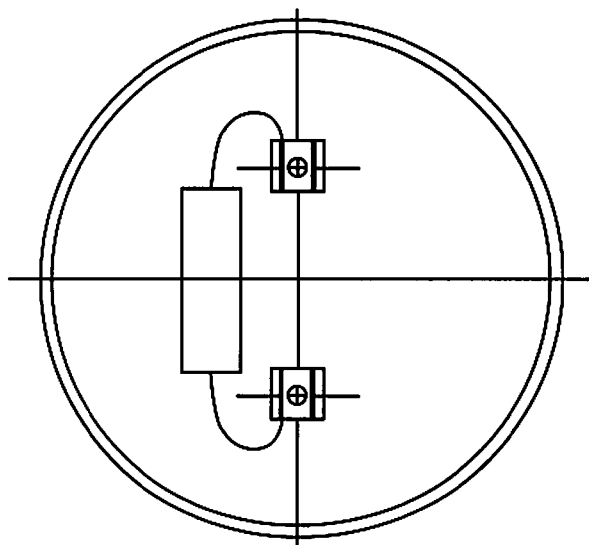

Figure 3-23. 15000 OHMS 2 WATT \pm 20% bleeder resistor wired across capacitor terminals.

B. Start Capacitor Substitution

If the specified start capacitor is not available, you may use the next larger sized MFD capacitor at the same or higher voltage rating. Do not add excessive starting capacitance.

C. Run Capacitors

Since January 1979, capacitors provided by Tecumseh have contained non-PCB oils or have been constructed using non-PCB impregnated metallized paper electrodes and polypropylene dielectric. These capacitors are protected against case rupture, if failure occurs, by a device within the capacitor can. The operation of this safety device could cause the terminal end to bulge outward 1/2". Suitable head space and/or rubber caps should be provided when installing such capacitors.

In some instances, for reasons of both space and economics, it is advantageous to use two capacitors whose MFD values add up to the total amount specified. In these cases, the capacitors should be connected in parallel. Rated voltage for each should not be less than that specified.

The tolerance on a run capacitor is $\pm 10\%$, and therefore only one rating figure is given. You should not go below this figure on any application. You may exceed this figure by a small amount, and the limits are shown in this table:

Table 3-8: Limits for Run Capacitor Ratings

Specific Rating	Maximum Addition
10 to 20 MFD	+ 2 1/2 MFD
20 to 50 MFD	+ 5 MFD
Over 50 MFD	+ 10 MFD

Remember the voltage rating of all capacitors must be the same or greater than the original rating. If you do not know the voltage, use 370 volt capacitors on 115 volt units and 440 volt capacitors on 230 volt units.



Table 3-7: Facts About Capacitors

Capacitor Type	Compressor Motor Type	Characteristics
Start Capacitor	CSIR and CSR	<ul style="list-style-type: none">• Designed to operate for only a few seconds during start• Taken out of start winding circuit by relay• Excessive start capacitor MFD increases start winding current, increases start winding temperature, and may reduce start torque• Capacitors in CSR motors should have 15,000 ohm, 2 watt bleed resistor across terminals• Capacitor rated voltage must be equal to or more than that specified• Capacitor MFD should not be more than that specified
Run Capacitor	RSIR, CSR, and PSC	<ul style="list-style-type: none">• Permanently connected in series with start winding• Excessive MFD increases running current and motor temperature• Fused capacitors not recommended for CSR and not required for PSC motors• Capacitor rated voltage must be equal to or more than that specified• Capacitor MFD should not exceed limits shown in Table 3-8 on page 32

VI. Identification of Terminal Pins

There are several different types of terminals used on the various models of Tecumseh compressors.

Tecumseh terminal pins are now always thought of in the order: Common, Start, Run. To identify the terminal pins, we read the order exactly as we would read a book: That is, we start at the top left hand corner and read across the first "line" from left to

right. We then drop down to the second line starting at the left and read across. Some compressor models have terminal pin identification embossed on the protective terminal cover. While the protective terminal cover may identify the terminal pins, it is primarily designed to reduce the risk of serious injury or death from electrocution or terminal venting with ignition. Never energize the system unless the protective terminal cover is securely fastened.

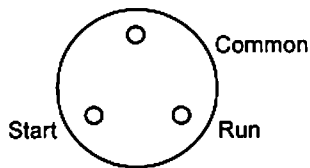

Push-On Terminal Pins
P, R, AP & AR Models (1953 to phaseout)
T & AT Models
AZ & AE (Refrigeration Models)

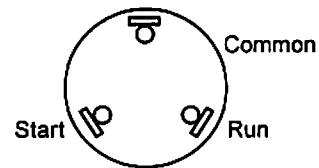

Spade Type Terminal Pins
AU & AR26 Air Conditioning Models
AE Air Conditioning Models
AW, AB, AJ, AH & RK Models

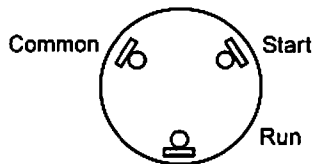

Spade Type Terminal Pins
S & C Models (1955 to phaseout)
AK Models

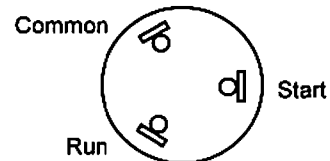

Spade Type Terminal Pins
AV Models

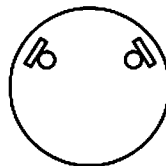

**Internal Thermostat
Terminal Pins**
Many CL Models

Figure 3-24. Current arrangements.