

Genetics of the Bombay Phenotype

By EDMOND J. YUNIS, JANET M. SVARDAL AND ROBERT A. BRIDGES

IN 1952 BHENDE ET AL.¹ described a new blood group related to the A-B-O system. This blood group is now generally called the Bombay phenotype.* Ceppellini² suggested that this blood group results from the presence of a homozygous recessive gene which inhibits the formation of A, B, and H antigens. Subsequently, Watkins and Morgan³ postulated that the H antigen might be the product of a gene independent of the A-B-O system, and that the Bombay phenotype is the rare homozygous *hh*. Levine et al.⁴ demonstrated in a family of Italian-American extraction that the Bombay phenotype effectively suppressed the expression of the B and secretor genes. This same family also showed that the *H-h* locus was not linked to the A-B-O locus.

A total of thirteen families with individuals of the Bombay phenotype have been reported from India.⁵⁻⁹ These have occurred in multiple castes and in both Hindus and Muslims. In addition, Italian-American,⁴ Irish,¹⁰ French-American,¹¹ English-American,¹¹ and German¹² family studies have been reported. Although the frequency of the *h* gene is quite low, it appears to be present in widely separated population groups. Bhatia and Sanghvi⁷ have estimated that one in seventy-seven Marathi speaking people may be heterozygotes.

The results of family studies, serologic and biochemical investigations have shown that the A, B, H and Lewis antigens (Le^a and Le^b) are the products of sequential action of transferases that modify a common precursor substance.^{13,14} The products of the A and B genes are glycosyl transferases that add either N-acetyl-galactosamine or galactose to the terminal galactose residue of the H substance. A fucosyl transferase is the product of the *H* gene and adds a fucose residue in 1→2 linkage to the terminal galactose residue of the precursor substance to produce the H antigen. Another fucosyl transferase, the product of the Lewis gene, may add another fucose residue in 1→4 linkage to the penultimate N-acetylglucosamine residue of either the precursor sub-

From the Department of Laboratory Medicine, University of Minnesota Hospitals, Minneapolis, Minn.

First submitted July 10, 1968; accepted for publication October 8, 1968.

EDMOND J. YUNIS, M.D.: *Professor and Director, Blood Bank and Immunology.*
JANET M. SVARDAL, M.S.: *Instructor, Department of Laboratory Medicine.* ROBERT A. BRIDGES, M.D.: *Associate Professor, Department of Laboratory Medicine, University of Minnesota Hospitals, Minneapolis, Minn.*

*Various notations have been employed to designate the Bombay phenotype. In this paper, we will refer to the normal allele as *H* and the mutant as *h*. The genotypes of the two homozygous types and the heterozygote may be written as *H/H*, *h/h* (the Bombay phenotype) and *H/h*. The use of the symbol *h* is not meant to imply that gene *h* produces some alternate gene product. From the study to be presented, we believe that the mutant is actually a deletion or inactivation of the *H* gene.

stance of the H substance to produce respectively the Lewis^a and the Lewis^b antigens.

This report describes a remarkably large family, spanning three generations that has a greater number of Bombay individuals than in any other previous report. These include the mother of the propositus, her sister, and five of her ten children. The father, although deceased, is presumed to be heterozygous at the Bombay (*Hh*) locus. This is also the first report of children born to parents of which one was homozygous and the other heterozygous at the Bombay locus.

The genetic analysis of the family reported in this article is compatible with a fairly common genetic mechanism that would explain both the widespread though limited occurrence of the Bombay phenotype and the existence of balanced polymorphism at the Lewis locus. We would suggest that the Lewis gene^{*} evolved from a duplication of the *H* gene and that the Bombay gene is the product of homologous but unequal crossing over that results in the deletion of the *H* gene.† Homologous but unequal crossing over in particular areas of the *H* and *Lewis* genes may also be used to explain both the Lewis-negative Bombay phenotype and the weak H and weak Lewis reactions that have been reported.^{9,15,16} The same mechanism with different cross-over products would also serve to maintain the Lewis-negative trait in a population as is presumed to be the case for certain haptoglobin types.¹⁷

MATERIALS AND METHODS

The propositus, a 33-year old male from Balassore, Orissa, India was found to be of the Bombay phenotype when admitted to the University of Minnesota Hospitals for elective surgery. The mother and the father of the propositus were cousins, but the degree was unknown. Blood samples were obtained from the relatives of the propositus in Balassore and neighboring towns of Orissa, India (Bengali language). Clotted and ACD preserved blood specimens, as well as saliva, were obtained when possible from all available members of the family. Saliva samples were heated in a boiling water bath for fifteen minutes after collection, centrifuged for 10 minutes, and the supernatant fluids separated. All blood and saliva samples were sent air mail to Minneapolis, Minnesota, U.S.A., and were studied within eight to ten days.

Standard methods were employed for all serologic investigations.¹⁸ Lewis substances in saliva and serum were determined as described by Wiener.¹⁹ Inhibition results are reported on saliva diluted 1:4 and 1:50. In general, nonsecretors have relatively large amounts of Le^a substance in their saliva which will neutralize Le^a antibody at both dilutions. Lewis-positive A-B-H secretor salivas contain both Le^a and Le^b substances. In such individuals, Le^a substance can be detected at the 1:4 dilution and Le^b substance is detected at a 1:50 dilution.

RESULTS AND DISCUSSION

The phenotypes of the red cells and the substances secreted in the saliva are shown in Tables 1 and 2. Erythrocytes from individuals identified as having

*Since the phenotype associated with the Lewis gene is modified by the secretor status of the individual, we have chosen to use the term Lewis positive for an individual expressing the Lewis gene and Lewis negative for the individual without the appropriate gene product. This seems to us clearer than the Le^{a+b-} Le^{a-b+} and Le^{a-b-} notation. We would then abbreviate the gene notation to *L/L*, and *L/1* for Lewis positive individuals and *1/1* for the Lewis negative individual.

†This hypothesis was originated by Robert A. Bridges.

Table 1.—ABO and Lewis Red Cell Phenotypes and Secretion of A, B, H, Le^a and Le^b Substances in the Saliva

Red Cell Phenotype			Secretion of A,B, H			Secretion of Le ^a and Le ^b Substances		
A-B-O	Lewis		In Saliva			Le ^a 1:4	In Saliva	
			A	B	H		Le ^a 1:50	Le ^b 1:50
I-2	Oh	Le ^{a+b-}	—	—	—	+ ^o	+	—
I-3	B	Le ^{a+b-}	—	—	—	+	—	—
I-4	Oh	Le ^{a+b-}	—	—	—	+	—	—
I-6	B	Le ^{a-b+}	—	+	+	+	—	+
I-8	B	Le ^{a+b-}	—	—	—	+	—	—
II-1	O	Le ^{a+b-}	—	—	—	+	+	—
II-2	Oh	Le ^{a+b-}	—	—	—	+	+	—
II-3	B	Le ^{a-b+}	—	+	+	+	—	+
II-4	B	Le ^{a-b+}	—	+	+	+	—	+
II-5	O	Le ^{a-b+}	—	—	—	+	—	—
II-6	B	Le ^{a+b-}	—	—	—	+	—	—
II-7	Oh	Le ^{a+b-}	—	—	—	+	+	—
II-8	Oh	Le ^{a+b-}	—	—	—	+	+	—
II-9	A	Le ^{a-b-}	—	—	—	—	—	—
II-11	B	Le ^{a-b-}	—	+	+	—	—	—
II-12	O	Le ^{a-b+}	—	—	+	+	+	+
II-13	Oh	Le ^{a+b-}	—	—	—	+	+	—
II-14	B	Le ^{a-b+}	—	+	+	+	—	+
II-15	B	Le ^{a-b-}	—	+	+	—	—	—
II-16	Oh	Le ^{a+b-}	—	—	—	+	+	—
II-17	B	Le ^{a+b-}	—	—	—	+	—	—
II-18	B	Le ^{a+b-}	—	—	—	+	—	—
II-19	B	Le ^{a+b-}	—	—	—	+	—	—
II-20 ^{o*}	B	Le ^{a-b-}	—	—	—	+	—	—
II-21	B	Le ^{a+b-}	—	—	—	+	—	—
II-22	B	Le ^{a+b-}	—	—	—	+	—	—
II-23	O	Le ^{a-b+}	—	—	—	+	—	—
II-24	A	Le ^{a-b+}	—	—	—	+	—	—
III-1 ^{o*}	B	Le ^{a-b-}	—	—	—	+	—	—
III-2	B	Le ^{a+b-}	—	—	—	+	+	—
III-3	B	Le ^{a-b-}	—	—	—	+	—	—
III-4	B	Le ^{a-b-}	—	—	—	+	—	—
III-5	B	Le ^{a-b-}	—	—	—	+	—	—
III-6	O	Le ^{a-b-}	—	—	—	+	—	—
III-7	A	Le ^{a-b-}	—	—	—	+	—	—
III-8	A	Le ^{a+b-}	—	—	—	+	—	—
III-9	B	Le ^{a-b+}	—	+	+	+	—	+
III-10	O	Le ^{a+b-}	—	—	—	+	+	—
III-11	B	Le ^{a+b-}	—	—	—	+	—	—
III-12	O	Le ^{a+b-}	—	—	—	+	—	—

* A+ indicates complete neutralization of .05 ml of Le^a or Le^b antisera at the indicated dilution of saliva.

† A-B-O and Lewis phenotypes determined from the serum only.

the Bombay phenotype failed to react with human anti-H serum, *Ulex europaeus* lectin, or anti-A or anti-B serum. Their sera contained A, B, and H antibodies. From the data presented in these tables, no genetic association

Table 2.—Red Cell Blood Factors Other than Those of the A-B-O and Lewis Systems

	<i>H</i>	<i>P₁</i>	<i>M</i>	<i>N</i>	<i>S</i>	<i>s</i>	<i>rh'</i>	<i>Rh_o</i>	<i>rh''</i>	<i>hr'</i>	<i>hr''</i>	<i>Fy_a</i>	<i>Fy_b</i>	<i>K</i>	<i>k</i>	<i>Jk_a</i>
I-2	—	—	+	—	+	+	+	+	—	—	+	+	+	—	+	+
I-3	+	—	+	+	+	—	+	+	—	—	+	+	—	—	—	—
I-4	—	+	+	—	+	—	+	+	—	—	+	+	+	—	+	+
I-6	+	—	+	+	+	—	+	+	—	—	+	+	—	—	—	—
I-8	+	—	+	—	+	—	+	+	—	—	+	+	—	—	—	—
II-1	+	—	—	+	—	+	+	+	—	—	+	+	—	—	+	—
II-2	—	—	+	—	+	+	+	+	—	—	+	+	+	—	+	+
II-3	+	+	+	—	—	+	+	+	—	—	+	+	—	—	+	+
II-4	+	—	+	+	—	+	+	+	—	—	+	+	—	—	—	—
II-5	+	—	+	—	+	—	+	+	—	—	+	+	—	—	—	—
II-6	+	+	+	—	+	+	+	+	—	—	+	+	+	—	+	+
II-7	—	—	+	—	+	+	+	+	—	—	+	+	—	—	+	+
II-8	—	—	+	—	+	+	+	+	—	—	+	+	—	—	+	+
II-9	+	—	+	+	—	+	+	+	—	—	+	+	—	—	—	—
II-11	+	+	+	—	+	+	+	+	—	—	+	+	—	—	—	—
II-12	+	—	+	+	—	+	+	+	—	—	+	+	—	—	—	—
II-13	—	+	+	—	+	+	+	+	—	—	+	+	+	—	+	—
II-14	+	+	+	—	—	+	+	+	—	—	+	+	—	—	+	+
II-15	+	+	+	—	+	+	+	+	—	—	+	+	—	—	+	+
II-16	—	+	+	—	+	—	+	+	—	—	+	+	—	—	+	—
II-17	+	—	+	—	+	—	+	+	—	—	+	+	—	—	—	—
II-18	+	—	+	+	+	—	+	+	—	—	+	+	—	—	—	—
II-19	+	—	+	+	+	—	+	+	—	—	+	+	—	—	—	—
II-20	+	—	—	—	—	—	—	—	—	—	—	—	—	—	—	—
II-21	+	—	+	—	—	+	+	+	—	—	+	—	—	—	—	—
II-22	+	—	+	+	+	—	+	+	—	—	+	+	—	—	—	—
II-23	+	—	+	—	+	—	+	+	—	—	+	+	—	—	—	—
II-24	+	—	+	—	—	+	+	+	—	—	+	+	—	—	—	—
III-1	+	—	—	—	—	—	—	—	—	—	—	—	—	—	—	—
III-2	+	—	+	+	—	+	+	+	—	—	+	+	—	—	—	—
III-3	+	—	+	+	—	+	+	+	—	—	+	+	—	—	—	—
III-4	+	—	+	—	+	—	+	+	—	—	+	+	—	—	—	—
III-5	+	—	+	—	+	—	+	+	—	—	+	+	—	—	—	—
III-6	+	—	+	—	—	+	+	+	—	—	+	+	—	—	—	—
III-7	+	—	+	+	+	—	+	+	—	—	+	+	—	—	—	—
III-8	—	—	+	+	—	+	+	+	—	—	+	+	—	—	—	—
III-9	+	—	+	—	+	—	+	+	—	—	+	+	—	—	—	—
III-10	+	—	+	—	+	—	+	+	—	—	+	+	—	—	—	—
III-11	+	—	+	+	—	+	+	+	—	—	+	+	—	—	—	—
III-12	+	—	+	+	+	—	+	+	—	—	+	+	—	—	—	—

can be demonstrated between the H locus and the MNSs, P, Rh, Kell, Kidd, or Duffy loci.

The family tree diagrams present only the data of the A-B-O, H-h, Lewis, and secretor systems. The portion of the family tree representing the mother and the siblings of the propositus is presented in Figure 1. The portion for the propositus' mother, her siblings, and their children is presented in Figure 2. Two individuals of Bombay type were identified in the first generation and five (the propositus and four siblings) in the second generation. Although the propositus (II-7) and his twin brother (II-8) have identical blood groupings, they are quite different in physical appearance and are probably nonidentical

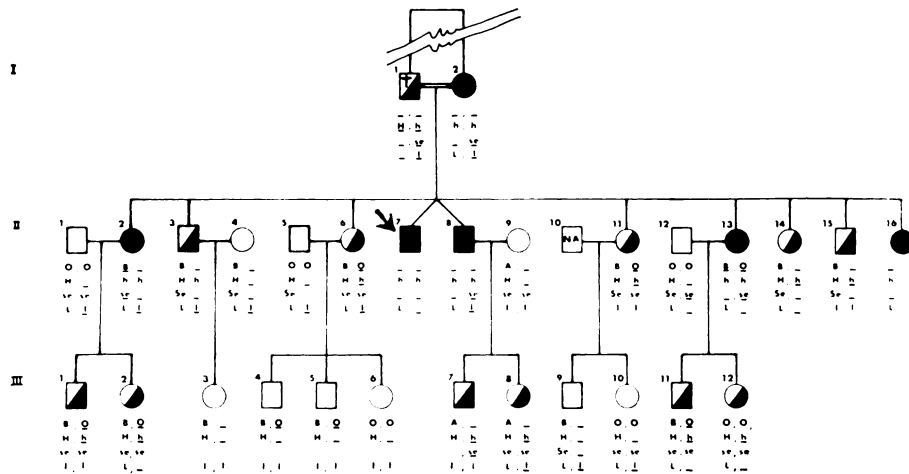

Fig. 1.—Family tree representing the propositus and his parents and siblings with their children. Only the ABO, H, Lewis and secretor systems are given in the diagram. In the genotypes given for each individual, those characters that have been inferred from the other data are underlined, while those characters directly determined are not underlined. The propositus is indicated by an arrow. Bombay homozygotes are indicated by solid figures, while heterozygotes by half-filled figures. Two individuals were not available (NA) for study and two others were deceased (†).

twins. The father of the propositus was presumably heterozygous at the Bombay locus since five of his ten children are of the Bombay phenotype.

The A-B-O types of the children of two Bombay individuals (II-2 and II-13) show that the *B* gene was present in the parent but effectively suppressed by the Bombay genotype. Suppression of the *B* gene by the Bombay genotype has been previously described by Levine.⁴ Suppression of the *A*₁ and *A*₂ phenotypes in Bombay individuals has also been described.¹¹ What is commonly referred to as suppression is actually a lack of expression if one assumes that H substance is required for the subsequent action of the A and B glycosyl transferases.¹³ Similarly, the A-B-H secretor status is not expressed in the absence of the *H* gene⁴ and *Le*^b substance is not produced as it is the product of action of both the *Lewis* and *H* genes.¹⁴

In the family of Levine et al.⁴ the linkage group associated with the *h* genes of the two parents had a common origin (first cousin marriage) and may be presumed identical. Thus Levine's family provides evidence against linkage of the A-B-O and H systems since one child of the propositus would have to have a *B, h* linkage group and the other child *O, h* linkage. In the present study, the mother of the propositus had two Bombay genes, of which only one could have the associated linkage group common to that of the father. These sibships, then, cannot be used as evidence either for or against linkage of the A-B-O and H systems.

Evidence for or against linkage of the *Lewis* and *H* loci cannot be obtained from this pedigree. However, children of three of the parents of Bombay phenotype (I-2, II-2, II-8) show that the parents must have been heterozygous at the *Lewis* locus. This has not been determinable in previously reported

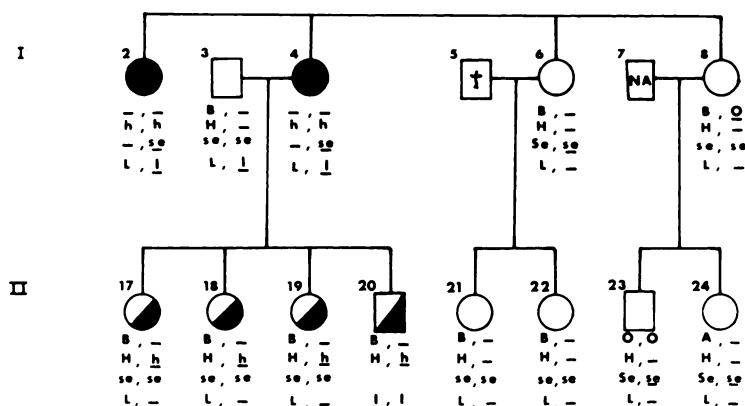

Fig. 2.—Family tree representing the mother of the propositus, her siblings and their children. The abbreviations used are the same as in Figure 1.

cases. Thus, there are individuals in this family possessing the h, L and/or h, l genes which are consistent with the scheme postulated by Watkins for two kinds of Bombay genotypes.¹³ There may be a significant excess number of Lewis-positive Bombay individuals. Only three Lewis-negative Bombay-type individuals have been reported.^{9,15,16} The erythrocytes of two of these were subsequently shown by Lodge et al.¹⁶ to react with certain rare Lewis antisera of such specificity as to suggest the presence of some intermediate substance.

Several theories have been proposed to explain the genetics of the Bombay phenotype. Ceppellini² anticipated that the Bombay phenotype results from the occurrence of homozygosity for a rare x gene which is not an allele of the ABO locus. Subsequently, he postulated that the xx genotype represents a metabolic block at the pre-H level.²⁰ Watkins and Morgan³ suggested that the H gene was independent of the A-B-O system and that the Bombay phenotype was due to homozygosity for the rare allele of H , i.e., hh . Homozygosity for a rare suppressor gene x was postulated by Levine⁴ who showed that the hypothetical $X-x$ genes were independent from the A-B-O locus. Wiener²¹ recently proposed the theory that Bombay individuals lack the gene X (i.e., xx) which determines the blood group precursor substance for the H, A and B antigens. This theory questions the concept that H substance is the precursor for A and B substances.¹³

A third possible explanation for the Bombay phenotype is presented here. The Bombay phenotype is postulated to be the result of inheritance of two chromosome regions containing deletions of the H gene caused by the mechanism of homologous but unequal crossing over. Up to the present time there is no knowledge of association of the H and *Lewis* loci, although Levine⁴ speculated that some association might exist. We postulate that the *Lewis* gene is the product of duplication of the H gene with subsequent divergent evolution. The H and *Lewis* loci are assumed to be linked and adjacent. This hypothesis is reasonable since both H and *Lewis* gene products are glycosyl transferases¹³ and each has fucose as a first substrate and the same oligosac-

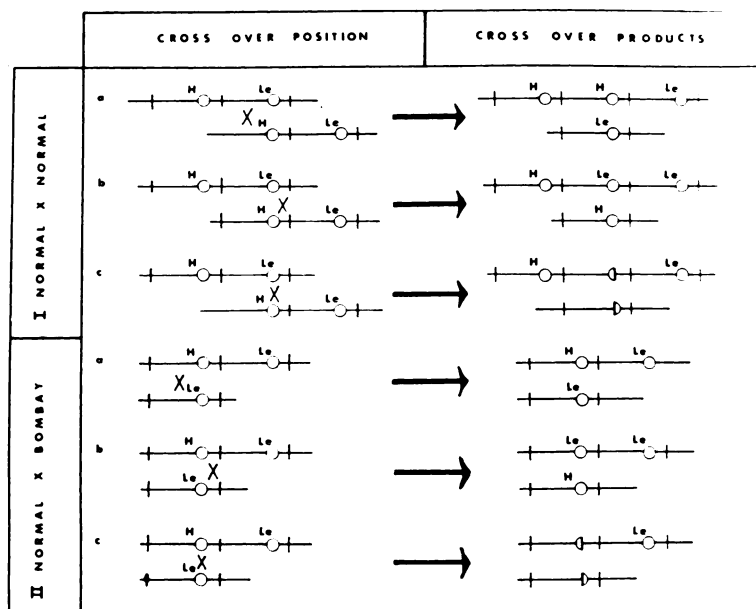

Fig. 3.—Diagrammatic representation of the possible products of homologous but unequal crossing-over between “normal” chromosomes (I) and between a normal chromosome and one with a deletion of the H locus (II). The position of the cross-over (X) determines whether there will be a duplication or a deletion of the H or Lewis loci. If the crossover occurs in a critical position it may also destroy the activity of that locus in both daughter chromosomes (denoted by $\text{---}<\text{---}$ and $\text{---}>\text{---}$).

charide as the second substrate. It might require only a small configuration change in the H specific enzyme to shift the position of the enzyme bound fucose by one residue to the penultimate residue. As little as one amino acid substitution could produce such a configurational change. In Figure 3 the possible homologous but unequal cross overs and their products are diagrammed. As shown in diagrams Ia, Ib, and Ic, there are three possible unequal cross over products between complete chromosomes as determined by the position of the cross over relative to that area determining the active site of the enzyme. The results are essentially the same whether they occur in a Lewis-positive homozygous or heterozygous individual. The products of Ia result in the production of a Lewis-positive chromosome with a deletion of the *H* gene and a chromosome with a duplication of the *H* gene. In the absence of methods sufficiently precise to demonstrate differences in gene dosage, the only demonstrable effects of such an event would be the production of a Bombay-type chromosome. If the cross over occurs on the other side of the active site (Ib), a deletion of the *Lewis* gene will occur. Such an event would serve as a mechanism for maintaining the Lewis-negative trait in different population groups. If the cross over should occur in the area determining the active site, (Ic and IIc), both H and Lewis activity of the resulting enzymes might be destroyed or severely altered. The restricted area required for such an event would explain the rarity of the Lewis-negative Bombay

phenotype. The products of homologous but unequal crossing over in the case of the Hh heterozygote would produce a Bombay chromosome from all three possible cross over positions (IIa, IIb, IIc). The products of a cross over at the active site (IIc) might result in the simultaneous production of both a Lewis-positive and a Lewis-negative Bombay-type chromosome.

The mother of the propositus then must be heterozygous for the two Bombay-Lewis linkage types, with one "Bombay gene" which has linked to itself an intact Lewis gene and the other which has a defective one. The father, it may be suggested, probably carried the more common Lewis-positive Bombay linkage type.

SUMMARY

Seven individuals with the Bombay phenotype have been found among the thirty-three members of an Indian family spanning three generations. This is the first report of children resulting from the union of an individual of the Bombay phenotype hh and an individual heterozygous Hh at the Bombay locus. This family again demonstrates the effective suppression of the A-B-O phenotype by the Bombay genotype. Three Bombay individuals of this family were shown to be heterozygous at the Lewis locus. This had not been determinable in previously reported cases. This is consistent with the concept that there are two kinds of Bombay genotypes. We propose that the Lewis gene has evolved from a duplication of the H gene. Such duplication predisposes to both higher orders of duplication and to deletion. Deletions in this system would then provide the genetic basis for the Lewis-negative and the Bombay phenotype. In order to explain the rarity of the Lewis-negative Bombay phenotype by the proposed mechanism, we postulate that it would only arise by crossing over at the position determining the active site of the transferase enzymes which determine the Lewis and the H specificities.

SUMMARIO IN INTERLINGUA

Septe individuos con le phenotipo Bombay esseva trovate inter le trenta-tres membros de un familia indian incluse representantes de tres generationes. Isto es le prime reporto de prole resultante ab le union de un individuo del phenotipo hh Bombay con un individuo heterozygotic Hh al loco Bombay. Iste familia demonstra de novo le efficace suppression del phenotipo ABO per le genotipo Bombay. Esseva monstrate que tres individuos Bombay de iste familia esseva heterozygotic al loco Lewis. Isto non esseva determinabile in previeamente reportate casos. Le facto es congrue con le conception que duo generes de genotipo Bombay existe. Nos postula que le gen Lewis ha evoluite ab un duplication del gen H . Un tal duplication predispone tanto a plus alte ordines de duplication como a deletion. Deletiones in iste systema providerea le base genetic pro le phenotype Lewis-negative e Bombay. Pro explicar le raritate del phenotype Bombay Lewis-negative per le proponite mechanismo, nos postula que illo occorre solmente per un transcruciamiento al position determinante le sito active del transferase que determina le specificitates Lewis e H.

ACKNOWLEDGMENT

The authors wish to thank Mrs. Helen Hallgren for her technical assistance and Mrs. Jane Swanson, Minneapolis War Memorial Blood Bank, for her generous provision of antisera of Le^a and Le^b specificities. Also, to Doctors Prasanta and Sukanta Dutta for their assistance in the collection of specimens.

REFERENCES

1. Bhende, Y. M., Deshpande, C. K., Bhatia, H. M., Sanger, R., Race, R. R., Morgan, W. T. J., and Watkins, W. M.: A new blood group character related to the ABO system. *Lancet* i:903, 1952.
2. Ceppellini, R., Nasso, S., and Tecilazich, F.: La Malattia Emolitica del Neonato. Instituto Sieroterapico Milanese Serafino Belfanti Milano: 204, 1952.
3. Watkins, W. M., Morgan, W. T. J.: Some observations on the O and H characters of human blood and secretions. *Vox Sang.* 5:1, 1955.
4. Levine, P., Robinson, E., Celano, M., Briggs, O., and Falkinburg, L.: Gene interaction resulting in suppression of blood group substance B. *Blood* 10:1100, 1955.
5. Bhatia, H. M., Sanghvi, L. D., Bhide, Y. G., and Jhala, H. I.: Anti-H in two siblings in an Indian family. *J. Indian Med. Ass.* 25:545, 1955.
6. Hakim, S. A., Vyas, G. N., Sanghvi, L. D., and Bhatia, H. M.: Eleven cases of Bombay phenotype in six families: suppression of ABO antigen demonstrated in two families. *Transfusion* 1:218, 1961.
7. Bhatia, H. M., and Sanghvi, L. D.: Rare blood groups and consanguinity: Bombay phenotype. *Vox Sang.* 7:245, 1962.
8. Bond, W. M., Shirgaonkar, N. V., Randeria, K. J., and Bhatia, H. M.: Unpublished case, 1965.
9. Bhatia, H. M.: Serology and genetics of the variants of the H antigen. *Indian J. Med. Res.* 54:345, 1966.
10. Parkin, D. M.: Study of a family with unusual ABO phenotypes. *Brit. J. Haemat.* 2:106, 1956.
11. Aloysia, M., Gelb, A. G., Fudenberg, H., Hamper, J., Tippett, P., and Race, R. R.: The expected Bombay group Oh A₁ and Oh A₂. *Transfusion* 1:212, 1961.
12. Pettenkofer, von H. J., Luboldt, W., Lawonn, H., and Niebuhr, R.: Uber genetische suppression der blutgruppen ABO Untersuchungen an einer familie bei der die unterdruckung nicht das blutgruppen merkmal B betrifft. *Z. Immun. Forsch.* 120:288, 1960.
13. Watkins, W. M.: Blood group substances. *Science* 152:172, 1966.
14. Marr, A. M. S., Donald, A. S. R., Watkins, W. M. and Morgan, W. T. J.: Molecular and genetic aspects of human blood-group Le^b specificity. *Nature* 215:1345, 1967.
15. Giles, C., Mourant, A. E., and Atabuddin, A. H.: A Lewis-negative Bombay Blood. *Vox Sang.* 8:269, 1963.
16. Lodge, T. W., Andresen, J., and Gold, E. R.: Observations on antibodies reacting with adult and cord Le (a-b-) cells, and Oh Le (a-b-) cells and a soluble antigen present in certain salivas. *Vox Sang.* 10:73, 1965.
17. Smithies, O.: Chromosomal rearrangements of protein structure. *Cold Spring Harbor Symposia on Quantitative Biology* 29:309, 1964.
18. Technical Procedures and Methods of the American Association of Blood Banks (ed. 4). Chicago, American Association of Blood Banks, 1966.
19. Wiener, A. S.: Lewis Blood Types: Theoretical implications and practical applications. *Amer. J. Clin. Path.* 43:388, 1965.
20. Ceppellini, R.: Physiological genetics of human blood factors. In *Biochemistry of Human Genetics*. Ciba Foundation Symposium. Boston, Little, Brown and Company. 1959.
21. Wiener, A. S., Moor-Jankowski, J., and Gordon, E. B.: The relationship of the H substance to the A-B-O blood groups. *Int. Arch. Allergy* 29:82, 1966.