

## Serology Review

---

- I. Introduction
- A. During this short rotation, you will review serology procedures.
  - B. Due to the limited number of serology procedures being performed at area clinical sites, the clinical experiences for serology will be performed on campus.
  - C. This rotation is set-up to resemble the clinical rotations you will experience in MLAB 2361 (Clinical II) and MLAB 2362 (Clinical III).
    - 1. The Serology Rotation laboratory *objectives* are structured like the objectives found in the Clinical II and III courses, they must be turned in to the course instructor for completion and will become part of your permanent record.
    - 2. You must post your clinical rotation activities in the Discussion Board. Appropriate posting serves as your “*log sheet*”. During this rotation, you will be prompted to make appropriate posts. Your postings will be part of the rotation grade.
    - 3. *Student Evaluation Form*: You will be observed and evaluated in the following areas:
      - a. Organization and performance of test
      - b. Interpretation and recording of results
      - c. Perform self-evaluation by completing the Student Evaluation Form. The instructor(s) will review and document their evaluation and add comments as necessary.
    - 4. *Site Evaluation Form*: At the end of each Clinical Practicum Rotation, an evaluation of the site/rotation is required. *Site Evaluation Forms* can be found in the student mailbox.
    - 5. *Clinical Rotation Examination*: The Serology Rotation Final will be administered at the end of the rotation period.
    - 6. *Rotation Study Questions*: While the study questions are not graded, they will be invaluable in preparation for the Serology Clinical Rotation exam. Review and pencil in the study question answers prior to the rotation, if possible.
  - D. This is a short rotation; be as prepared as possible by reviewing previously covered immunology / serology lecture and lab information as well as study questions ahead of time.
  - E. For each serology test presented and discussed, you should become familiar with:
    - 1. The principle of the test, including type and preferred condition of the specimen.
    - 2. The substance being detected and/or identified
    - 3. The quality control required and corrective action to take when it does not fall within the expected parameters.
    - 4. The reaction involved.
    - 5. What constitutes a positive or negative test.
    - 6. Clinical significance of a positive or abnormal result, including correlating the results with the patient’s condition.
    - 7. Limitations of the test procedure.

## **Serology Review**

---

### II. Review of Immunology

- A. *Immunology* - a study of the principles of *immunity*
- B. Deliberate attempts to induce immunity through inoculation began in 1500 AD (Jenner).
- C. Edward Jenner - noted work using cowpox to immunize against smallpox
- D. Louis Pasteur - noted work used attenuated rabies virus to provide immunity
- E. Antigen (immunogen) - a foreign substance of a sufficient molecular weight and complexity that when placed in a capable host will invoke an immune reaction as demonstrated by the production of antibodies (a humoral response) which are capable of reacting specifically with that antigen.
  - 1. Characteristics of a good immunogen:
    - a. Foreign to the host
    - b. Size
      - (1) Molecular weight must be at least 10,000.
      - (2) Substances below 5000 Daltons rarely simulate antibody production.
    - c. Molecular complexity and rigidity
      - (1) Proteins
        - (a) glycoproteins
        - (b) lipoproteins
        - (c) nucleic acids
      - (2) Polysaccharides
      - (3) Lipids - generally non-immunogenic, but may be haptens
    - d. Genetic factors
    - e. Route of administration and dose
  - 2. Haptens
    - a. Antigen attached to a larger molecule.
    - b. Cannot initiate an immune response unless coupled to a large molecule
  - 3. Related Terms
    - a. Chemotaxis
    - b. Opsonization -
    - c. Epitope / Antigenic Determinant -

## Serology Review

---

- d. Heterophile antigen - antigens that appear on the surface of tissues of several different species. Antibodies produced to one can cross react with the antigen of the other members (making them heterophile antibodies).
- e. Antibody - a specific protein produced in response to and immunogen; will react with an antigen.

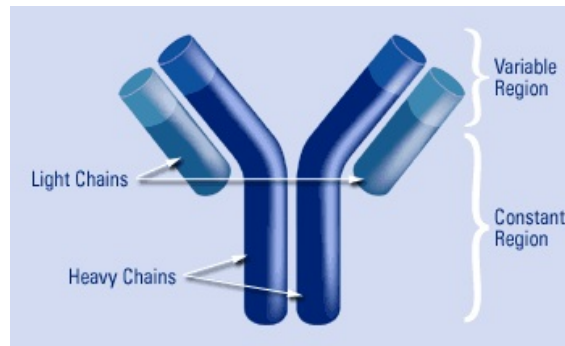

### F. Antibodies

1. Where do they come from?
2. What cell line is responsible?
3. Antibodies may be produced in response to antigens of another member of the same species (*alloantibodies*), another species (*xenoantibodies* or *heterophile antibodies*), or from antigens possessed by that same individual (*autoantibodies*).
4. Belong to a family of proteins known as immunoglobulins (Ig), which have same basic structure (two light chains - kappa or lambda; and two heavy chains held together by disulfide bonds)
5. Five types of heavy chains (making up the five classes of immunoglobulins) may be combine with either type of light chain (kappa or lambda, but never both).
6. The *antigen binding site* is at the end of the heavy and light chains in the variable portion of the molecule. (Fab area)
7. Use of enzymes (papain and pepsin) has assisted in the identification of specific areas of the immunoglobulin's structure.
  - a. Fab (**F**ragment capable of **A**ntigen **B**inding) - involved in antigen binding.
  - b. Fc (**F**ragment **C**rystalline) - directs the biological activity of the antibody.
  - c. Papain will split the antibody into three fragments - 2 Fab and 1 Fc
  - d. Pepsin results in two slightly different Fab fragments known as F(ab')<sub>2</sub> which have the ability to bind antigen.

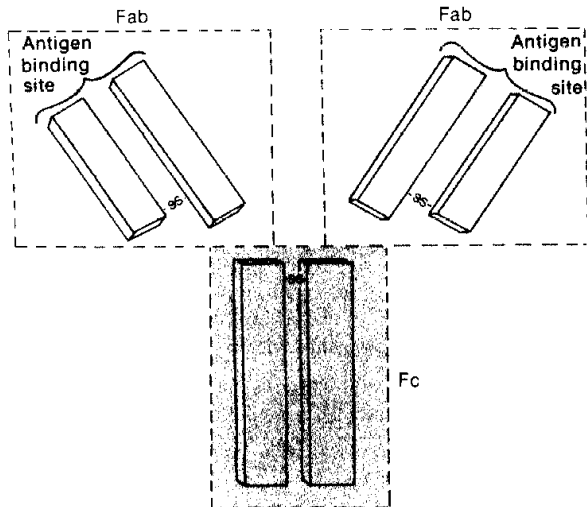

Cleavage of antibody molecule by papain.

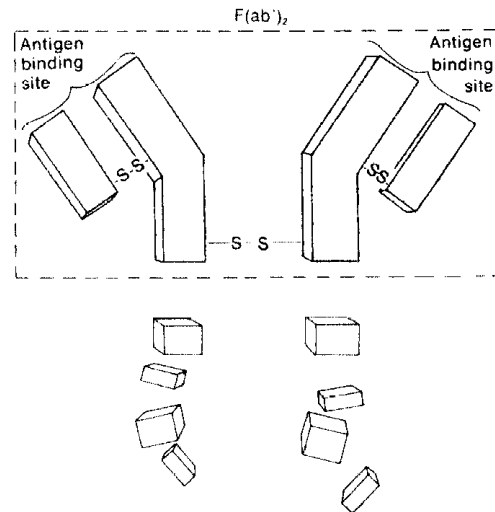

Cleavage of antibody molecule by pepsin.

8. Immunoglobulin molecules combine with antigen of cellular surfaces, resulting in the destruction of the cell either *extra vascularily* or *intravascularily* - enlisting the aid of *complement*.
9. Immunoglobulin molecules are also responsible for the *neutralization of toxins* and facilitation of *phagocytosis*.
10. Five immunoglobulin classes (as determined by the **heavy chain**, constant region)
  - a. IgG (gamma); heavy chains are gamma
    - (1) 85% of the total immunoglobulin (800-1680 mg/dL)
    - (2) Monomer - one basic structural unit, 7S globulin (mw 150,000 Daltons)
    - (3) Four subclasses; IgG<sub>1</sub>, IgG<sub>2</sub>, IgG<sub>3</sub>, IgG<sub>4</sub>, - based on structural and serological differences
    - (4) Capable of changing shape to accommodate antigen or to expose hidden sites with responsibility for other functions, ie. binding complement, etc.
    - (5) Only immunoglobulin to cross placenta, facilitated by site on Fc fraction which allows for attachment to placental tissue.
    - (6) Provides for secondary immune response
  - b. IgM (mu); heavy chains are mu
    - (1) 5-10% (80-170 mg/dL)
    - (2) Pentamer - 19 S macroglobulin with mw of 900,000 Daltons. Five basic structural units joined by J-chain who's function is not completely understood.
    - (3) No subclasses
    - (4) Flexible in shape, hinge area allows for numerous shapes
    - (5) Does not cross placenta
    - (6) Responsible for primary immune response
  - c. IgA (alpha heavy chains)
    - (1) 10-15% (@ 225 mg/dL) - 40% of which is intravascular
    - (2) Basic structural unit has MW of 160,000. Varies somewhat in structural form with monomer and dimer forms.

## Serology Review

---

- (3) In serum, 90% is in monomer form. SIgA dimer (two structural forms joined with a J-chain, similar to IgM) form is more likely to be found in body secretions. A small additional structure, the *secretory component*, required.
  - (4) Does not fix complement or cross placenta
  - (5) SIgA involved in first line of defense.
- d. IgE (epsilon heavy chains)
- (1) 1-10% of total (normally <1.0 mg/dL in normal persons, but may be 10x higher in highly allergic individuals)
  - (2) Plays large role in allergic response
  - (3) Also called reagin, an antibody in the serum of allergic persons.
  - (4) Composed of 2 heavy chains, + 2 light chains, cannot fix complement
  - (5) Not completely understood.
- e. IgD (delta heavy chains)
- (1) Found in minute quantities (3.0 mg/dL)
  - (2) Function/contribution unknown
11. Antibodies as reagents
- a. Animal production
  - b. Monoclonal antibodies

### G. The Immune Response

1. *Natural resistance/immunity* - the ability of an individual to resist infections through the normally present body functions. Includes the following concepts:
  - a. susceptibility and non-susceptibility
  - b. intact first line of defense; epithelial barriers (skin, mucous membranes)
  - c. inflammation
  - d. phagocytosis
  - e. complement activation
2. *Immunological tolerance* - when a recipient fails to respond to antigenic stimulus.
  - a. repeated injection or exposure, ie. use of modified antigens in allergy shots.
  - b. animals are tolerant of antigens encountered during embryonic life (recognition of "self" antigens)
  - c. *high-dose tolerance or immunological paralysis* - may result when an individual receives very large dose on an antigen
3. Factors that influence immune response
  - a. Genetic factors
  - b. Age of recipient
  - c. Method of administration
    - (1) Dose - how much was inoculated
    - (2) Route - under the skin is better than IV or GI
    - (3) Adjuvant enhancement?
4. Humoral immunity - production of antibodies by B-lymphocytes and plasma cells in response to specific antigens
  - a. B-cells Bursa or bone marrow derived lymphocytes
    - (1) 10-20 % of peripheral blood lymphocytes have B-cell characteristics
    - (2) short life span of 3 days

## Serology Review

---

- (3) antigenic receptors on B-cells are immunoglobulins
- (4) Following encounter with foreign antigen, complex series of events occurs including production of memory cells, interaction with T-cells, dedifferentiation to produce the efficient antibody producing *plasma cells*.

b. Cell-mediated immunity - activities of T-lymphocytes

- (1) T-cells Thymus derived.
- (2) half life of 2.2 years. May live 20 years

T helper	stimulates B-cell in its immunoglobulin response (B-lymph transformation to plasma cell)
T suppressor	inhibit B-cell response to antigen stimulation
T cytotoxic (killer)	have the ability to destroy specific antigens or antigen bearing target cells (T-effector)

H. The Production of Antibodies

1. *Primary immune response*

- a. Follows first encounter with foreign antigen
- b. Antibody production is usually slow, dependent on the dose of challenging antigen. (several days to two weeks)
- c. Titers may rise rapidly for several weeks, peak, then begin a slow decline.
- d. Without further stimulation, antibody level will remain low for a prolonged period of time, or disappear altogether.
- e. Although generally associated with the production of IgM class antibodies, IgG class may also be produced.

2. *Secondary (anamnestic) response*

- a. Occurs after the second or subsequent encounter with the same foreign antigen.
- b. Response is rapid and more intense as the result of immunological memory.

3. *Tolerance (immunological tolerance)* - when a recipient fails to produce an antibody .

I. Active immunity

J. Passive immunity

III. Complement

- A. Term refers of a complex set of nine distinct proteins which react sequentially to cause such biological effects as *immune adherence*, *phagocytosis*, and *cell lysis*.
- B. IgM and IgG (subclasses 1,2, and 3; but not 4) class antibodies capable of activating complement cascade.

## Serology Review

---

- C. Numerous checks and balances.
  
- D. Classical pathway
  - 1. C1
    - a. C1 is a macromolecular complex of three subcomponents, C1q, C1r, and C1s held together by ionized calcium.
    - b. For C1 to be activated, two antigen-bound Fc fragments are required to be bound to adjacent antigen sites. This would require 2 IgG molecules, while only 1 IgM is capable of complement activation.
    - c. C1q attaches to the complement activation site of (1) IgM or (2 appropriately placed) IgG molecules (attached to their appropriate antigens). This attachment sterically distorts the C1r subcomponent, which in turn distorts the C1s subcomponent. The activated C1s affects other plasma proteins, C4 and then C2.
    - d. The process of complex interactions of the complement plasma proteins and cell bound complement proteins continues. A number of the plasma proteins are split resulting in a subcomponent that attaches to the foreign cell, and the other subcomponent remaining in the plasma often having an inflammatory effect.
    - e. The outcome of this activity is the formation of a “hole” in the cell membrane of the intruding cell resulting in its loss of contents and lysis.
    - f. Summary of complement activation sequence: C1, C4, C2, C3, C5, C6, C7, C8, and C9.
  
- E. Alternative / Properdin pathway
  - 1. No participation of C1, C4, or C2
  - 2. Activation occurs through stimulus by aggregates of IgA, or by naturally occurring polysaccharide and lipopolysaccharide ( as might occur on the cell walls of certain bacteria).
  - 3. Additional factors (I, B, D) involved. Upon activation, there is an alteration of C3, splitting it into its “a” and “b” subcomponents after which the pathway activation is the same as for the classical.
  - 4. The order of activation of the components (following activation): C3, C5, C6, C7, C8, C9.
  
- F. Lectin Pathway
  - 1. The lectin pathway is homologous to the classical pathway, but with the opsonin, mannose-binding lectin (MBL) and ficolins, instead of C1q.
  - 2. This pathway is activated by binding mannose-binding lectin to mannose residues on the pathogen surface, which activates the MBL-associated serine proteases, MASP-1 and MASP-2 (very similar to C1r and C1s, respectively), which can then split C4 into C4a and C4b and C2 into C2a and C2b. C4b and C2a then bind together to form the C3-convertase, as in the classical pathway.

## Serology Review

---

3. The biological activities and the regulatory proteins of the lectin pathway are the same as those of the classical pathway.

### G. Destruction or degradation of complement *in vitro*

1. Anticoagulants - chelating calcium
2. Heating - (56° C for 30 min)
3. Normal serum inhibitors
4. Storage

### H. Review of terms

1. *Sensitization* - the combination of antigen and antibody, with or without subsequent agglutination.
2. *Agglutination* - clumping, the fundamental reaction between antigen and corresponding antibody
3. *Hemagglutination* - a specific type of agglutination; the aggregation of red cells into clumps.
  - a. Usually the antigen is a part of the RBC and is called the *agglutigen*.
  - b. The antibody is referred to as the *agglutinin*.
  - c. Hemagglutination reactions are usually graded from 0, indicating no agglutination, to 4+ where all cells are agglutinated.
4. *Hemolysis* - the breakdown / lysis of red cells resulting in the loss of hemoglobin. Antibodies having this capacity (through the action of complement) are called *hemolysins*.
5. *Precipitation* - the interaction of soluble antigen and antibody in optimal proportions resulting in the formation of a visible precipitate.
6. *Inhibition* - the suppression of an antigen-antibody reaction caused by the soluble antigen binding all of the antibody sites, therefore *neutralizing* its activity.
7. *Complement fixation* - involves the binding of complement by antigen-antibody aggregation and the lysis of the sensitized cells.
8. *Titration* - a serological method of determining the amount of a specific antibody by making a series of dilutions of the patient's serum, and testing them against the corresponding antigen.

## IV. Review of Serology

### A. Principles of Serological Testing

1. Specificity vs Sensitivity

*Specificity* - how true the test result. Indicates the relative absence of cross-reactivity by the antibodies with substances that are closely or chemically related to the inciting antigen.

## Serology Review

---

*Sensitivity* - how small of an amount can be detected. Indicates the smallest amount of the substance being tested (could be either antigen or antibody) that will demonstrate a positive reaction.

2. Biological false positives - Term used when there is cross reaction with natural substances other than the one being tested.
3. Factors affecting antigen - antibody reactivity
  - a. Time of incubation
  - b. Temperature of incubation
  - c. pH of test system
  - d. Antigen and Antibody concentration
    - (1) Excess of antibody
    - (2) Excess of antigen -
    - (3) Zone of equivalence - the narrow range at which antigen and antibody are in optimal concentrations
      - (a) Sensitization
      - (b) Lattice formation resulting in agglutination / precipitation
4. Precipitation - Term used to describe the resultant reaction of an antibody and its corresponding *soluble* antigen.
  - a. Fluid precipitation tests
    - (1) Antigen and antibody are free reactants
    - (2) Prozone / postzone and cross reaction problems are common.
    - (3) Example: C-reactive protein
  - b. Gel precipitation tests
    - (1) Soluble antigen and/or antibody diffuse through pores of a gel until their concentrations reach optimal ratios resulting in a stable immunoprecipitate
    - (2) Types
      - (a) Single diffusion - only one reactant (usually antigen) is moving

Example: RID tests (concentration of immunoglobulins, hapoglobin and other proteins) - antibody is dispersed throughout agar. Compare ring size of unknowns to that of standards (like a curve). If unknown's ring size exceeds that of greatest standard, must dilute and repeat test.

## Serology Review

---

- (b) Double diffusion - both antigen and antibody moves through the gel medium.

Example: Ouchterlony gel diffusion

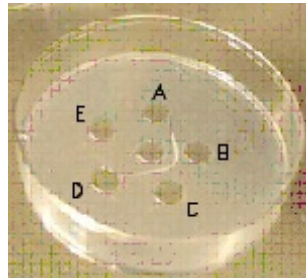

- (3) Other terms used to describe the direction of movement
- Single dimension - occurs in a tube, movement is up or down
  - Double dimension - occurs in a gel medium, movement is radially
5. Electrophoresis - Process of separating proteins in a mixture utilizing their differing net electrical charges. When placed in a suitable buffer, a electrical current will cause the proteins to migrate at a rate dependent on their charge.
- Moving boundary electrophoresis
  - Disc electrophoresis
  - Zone electrophoresis
  - Immunoelectrophoresis - Process of separating protein mixtures of protein antigens whereby they are first electrophoresed then antibodies are added resulting in the formation of bands (arcs) of immunoprecipitates where antigens and homologous antibodies have combined.
6. Capsular precipitation - encapsulated bacteria seem to swell when exposed to homologous antisera
- Quelling reaction
  - Used for typing and identifying *Haemophilus influenzae*, *Klebsiella pneumoniae*, and *Neisseria meningitidis*
7. Agglutination - immunological aggregation or clumping of insoluble particles

## V. Serological Tests

### A. Syphilis

- Caused by spirochete *Treponema pallidum*.
- Early syphilis - demonstration of lesion (chancre); 90% patients sero-positive within 3 weeks.
- Secondary syphilis - 6-8 weeks after chancre, patient highly infectious, tests ! 100% positive. Patient may develop generalized rash.
- Latent syphilis - sero tests still reactive, but clinical signs of disease absent. While patient may not be contagious sexually, transplacental transmission possible.
- Tertiary syphilis - May occur many years later. New lesions (gummata) may appear in nearly any body location.
- Others (cardiovascular, neuro-, congenital) -

7. Testing
    - a. Tests for non-treponema antibody / reagin
      - (1) VDRL (a flocculation reaction)
        - (a) Pre treat serum - 56 degrees for 30 minutes. Testing must occur within next 4 hours, or pretreatment must be refreshed.
        - (b) Antigen composition
          - i) Cardioliipin
          - ii) Cholesterol added
          - iii) Lecithin added
      - (2) Recommended screening test for CSF specimens.
      - (3) Test read microscopically
    - b. RPR
      - (1) No pre-treatment of serum needed
      - (2) Uses modified VDRL cardioliipin antigen
      - (3) Read macroscopically
      - (4) Cannot use for CSF specimens
  8. Tests for treponema antibodies
    - a. FTA-ABS (fluorescent treponema antibody)
    - b. TPI (*Treponema pallium* inhibition)
    - c. THA (*Treponema pallium* hemagglutination)
- B. Lyme's Disease
1. Causative agent ***Borrelia burgdorferi***
  2. Stages of disease
    - a. **Localized rash.**
    - b. Dissemination to multiple organ systems
    - a. Chronic disseminated
  3. Diagnosed clinically confirmed serologically.
    - a. Antibodies to antigens of *B. burgdorferi* can be detected by latex agglutination, IFA, ELISA and Western Blot.
    - b. Serological tests are often falsely negative during early weeks.
    - c. Western Blot is most sensitive.
      - (1) The western blot (alternately, immunoblot) is a method to detect a specific protein in a given sample of tissue homogenate or extract.

- (2) It uses gel electrophoresis to separate native or denatured proteins by the length of the polypeptide (denaturing conditions) or by the 3-D structure of the protein (native/ non-denaturing conditions).
- (3) The proteins are then transferred to a membrane (typically nitrocellulose or PVDF), where they are probed (detected) using antibodies specific to the target protein.

d. IFA and ELISA are more commonly performed due to ease of procedure, but are subject to false positives due to other spirochete diseases and some autoimmune diseases

### C. C-Reactive Protein

1. A non-specific protein that appears in serum as a response to inflammatory conditions / tissue necrosis and disappears when condition has subsided.
2. Often seen in bacterial and viral infections, active rheumatic fever, active rheumatoid arthritis, TB infections, malignant diseases, and following surgery.
3. More sensitive than ESR
4. Latex agglutination tests - Latex particles coated with anti-CRP agglutinate when mixed with patient serum containing the CRP antigen

### D. Group A Streptococcal Infection

1. Causative agent *Streptococcus pyogenes*
  - a. This organism is the principle cause of oropharyngitis which can lead to complications.
  - b. Sequelae include **Rheumatic Fever** and **Acute Glomerulonephritis** which can only be diagnosed through testing for specific antibodies.
2. Culture and rapid screening tests detect early infection.
3. Hemagglutination tests
  - a. Numerous exoantigens are produced and excreted as the cell metabolizes:
    - (1) Streptolysin O
    - (2) Dnase
    - (3) Hyaluronidase
    - (4) Nicotinamide
    - (5) Adenine dinucleotidase (NADase)
    - (6) Streptokinase
  - b. Red cells coated with the extracellular enzymes of streptococcus are mixed with patient serum.
  - c. Agglutination is a positive test
4. ELISA and molecular testing becoming popular.

## Serology Review

---

### E. Cold Agglutinins

1. A transient antibody that appears in the serum of patients with primary atypical pneumonia caused by *Mycoplasma pneumoniae*.
2. These antibodies, with anti-I specificity, react with all adult RBCs at temperatures 0-10°C, but dissociate from the cell at temperatures greater than 25°C.
3. Fourfold (or more) rise in titer is significant.
4. Specimen handling precautions
  - a. Specimen should be collected and maintained in warm tube until serum can be separated from cells.
  - b. Failure to do so will result in \_\_\_\_\_.

### F. Rheumatoid Arthritis

1. Chronic inflammatory disease, of unknown origin, that affects primarily joints and periarticular tissues.
2. Felty's syndrome is combination of anemia, arthritis and splenomegaly.
3. Rheumatoid factor (RF)
  - a. Group of immunoglobulins (IgM) that interact specifically with antigenic determinants on IgG molecules (anti-antibody), ie, it is an IgM antibody directed specifically at IgG.
  - b. RF can occur in non-rheumatoid, chronic infective conditions such as LE, infectious hepatitis, chronic hepatic disease, syphilis, etc.
4. Testing
  - a. Designed to detect certain macroglobulins (IgM) in patient serum that react with normal human or animal IgG (anti-antibody)
  - b. Majority of tests utilize IgG coated latex particles - this is a prime example of an antibody acting as the antigen.
  - c. Latex allows the reaction between RF and IgG to become a visible agglutination reaction.

### G. Infectious Mononucleosis (IM)

1. Causative agent Epstein-Barr Virus (EBV)
2. Forssman antigen, an example of a heterophile antigen and the terms often used interchangeably
  - a. Any substance that will stimulate the formation of a sheep RBC hemolysin.
  - b. They are found on the RBCs of many animals, including man.
3. Forssman antibody (a heterophile antibody)
  - a. Cross reacting, non-specific heterophile antibodies.

## Serology Review

---

### 4. Tests

#### a. Paul - Bunnell test

- (1) Sheep RBCs are added to dilutions of patient serum
- (2) Agglutination indicates the presence of any of the following:
  - (a) serum sickness antibody
  - (b) Forssman antibody
  - (c) IM antibody
- (3) No agglutination = no antibody present
- (4) Positive agglutination = presumptive for IM, more (specific) testing necessary

#### b. Davidson Differential Test

- (1) Selectively absorb out the antibodies that cause positive PB reaction using guinea pig kidney tissue and beef RBCs.
- (2) Absorption pattern

Type of Heterophile Antibody	Absorption by Guinea Pig Kidney tissue	Absorption by Beef RBCs
1. IM	NO	YES
2. Forssman	YES	NO
3. serum sickness	YES	YES

- c. Slide tests - Based on reaction of IM antibodies with horse RBCs. Agglutination of horse RBCs is indicative of presence of IM antibody. No absorptions necessary.

### H. Rubella

#### 1. General information

- a. RNA virus causing 3-day / German measles
- b. Spread by direct contact or droplets from infected person.
- c. Though highly contagious, infection is benign to most.
- d. Congenital infections

#### 2. Vaccination (MMR) at 15 months of age

#### 3. Lab testing - serology testing rather than viral tests as body usually gives quick response with production of IgM antibody.

- a. Complement fixation - older, classical test method.
- b. Hemagglutination inhibition -
- c. Passive Hemagglutination
- d. Neutralization
- e. Hemolysis in gel
- f. Fluorescence immunoassay
- g. Radioimmunoassay

## Serology Review

---

- h. Latex agglutination
- i. ELISA- Popular, but some problems with non-viral contaminants. Used to use whole virus, but now use synthetic peptides to overcome test difficulties.

### I. Pregnancy Testing

1. Human Chorionic Gonadotropin (HCG) - glycoprotein hormone produced in increased amounts in pregnant women. Consists of two non-covalent linked subunits,  $\alpha$  and  $\beta$ . The  $\alpha$  subunit is identical to the  $\alpha$  subunits in many other hormones (luteinizing, follicle-stimulating, and thyroid-stimulating hormones)
2. Specimen requirements
  - a. Serum for quantitative analysis
  - b. Urine
    - (1) first morning collection with specific gravity of at least 1.015
    - (2) fresh specimen, no more than 12 hours old
    - (3) specimens should be refrigerated (up to 24 hr.) if not tested immediately, can be stored frozen
    - (4) can not have excessive blood or significant bacteria
3. Radioimmunoassay testing
  - a. utilize radioactively tagged particles
  - b. Quantitative measurement
  - c. Can determine gestational age
4. Enzyme linked immunosorbent assay (ELISA)
  - (1) Sandwich technique, utilizes monoclonal anti-HCG antibody bound to membrane. When urine is filtered through membrane, HCG becomes bound to this fixed antibody.
  - (2) Addition of a soluble anti-HCG that is tagged with an enzyme results in this antibody binding to another site of the HCG.
  - (3) Chromogen and substrate reagents are added which are catalyzed by the enzyme to form a color, if the HCG was present in the specimen.
  - (4) Sandwich technique - anti-HCG/HCG/anti-HCG with indicator
  - (5) Qualitative test.
  - (6) These monoclonal tests can detect HCG as early as 7-10 days following conception.
5. HCG in non-pregnancy/other conditions
  - a. Hydatidiform mole
  - b. Germ cell tumors
    - (1) choriocarcinoma
    - (2) teratoma
    - (3) seminoma
    - (4) embryonal carcinoma

### J. Haptoglobin

1. Protein that binds free hemoglobin to prevent loss through kidneys
2. Whenever free serum hemoglobin rises (ie due to hemolysis), serum haptoglobin levels drop

## Serology Review

---

3. Use also as an indicator of acute or chronic inflammatory conditions including neoplastic disease, where increased levels are seen or to monitor hemolysis which will result in decreased levels.
4. Test methods include: RID, Immunoturbimetric, neutralization technique.
5. Normal levels vary depending on methodology and other factors. General reference level @ 30 - 200 mg/dL. Patient clinical history and results of other tests should be evaluated at same time.

### K. Hepatitis

1. Five distinct hepatitis viruses, A, B, C, D and E which cause chronic and acute hepatitis.
2. All of these are RNA viruses with the exception of **hepatitis B which is a DNA virus.**
3. Hepatitis A and E ***transmitted by fecal-oral route***, usually associated with unsanitary conditions or contaminated food or water.
4. Hepatitis D requires infection with Hepatitis B to be present.
5. Chronic carrier state may develop and may result in liver failure due to cirrhosis, hepatocellular carcinoma, or fulminant hepatitis
6. Fulminant hepatitis is the term used when the number of hepatocytes destroyed is so great that too few remain to maintain basic liver function, results in liver failure.
7. Laboratory diagnosis of Hepatitis B involve the detection of three marker systems.
  - 1) **Hepatitis B surface antigen (HBsAg) is the first to appear**, appears 2 to 4 weeks during late incubation, marker of choice for recent infection.
  - 2) **Anti-Hepatitis B surface antigen (anti-HBs) is the last antibody to appear**, may persist for life.
  - 3) Between disappearance of HbsAg and appearance of anti-HBs is known as the **core window**.
  - 4) **IgM antibody to hepatitis B core antigen (anti-HBc)** may be the only detectable marker during the core window, differentiates recent infection from chronic carrier state.
  - 5) Third marker is hepatitis Be antigen (HBeAg), appearance of HbeAg and anti-HBe, closely coincide with HbsAg.
8. Hepatitis C - nucleic acid testing to detect presence of virus.

### L. Human Immunodeficiency Virus (HIV)

1. Etiologic agent of Acquired Immunodeficiency Syndrome (AIDS).
2. Icosahedral, enveloped virus of the lentivirus subfamily of retroviruses which transcribe RNA to DNA.

3. Testing
  - a. ELISA Testing
  - b. Agglutination tests using latex particles, gelatin particles or microbeads are coated with HIV antigen and will agglutinate in the presence of antibody.
  - b. Dot-Blot Testing utilizes paper or nitrocellulose impregnated with antigen, patient serum is filtered through, and anti-antibody is added with enzyme label, color change is positive.
  - c. Western Blot Testing- most popular confirmatory test.
  - d. Indirect immunofluorescence assay can be used to detect both virus and antibody to it.
  - e. Detection of p24 HIV antigen
  - f. CD4/CD8 ratio
  - g. Polymerase Chain Reaction - Looks for HIV DNA in the WBCs of a person
  - h. Viral Load Tests